

MATERIAL WALL THICKNESS (T)
 PRECAST CONCRETE MIN. $\frac{1}{2}$ "D"
 CAST-IN-PLACE CONC. MIN. 6"

* VACUUM TESTING SHALL BE REQUIRED
 PER ASTM C-1244-02

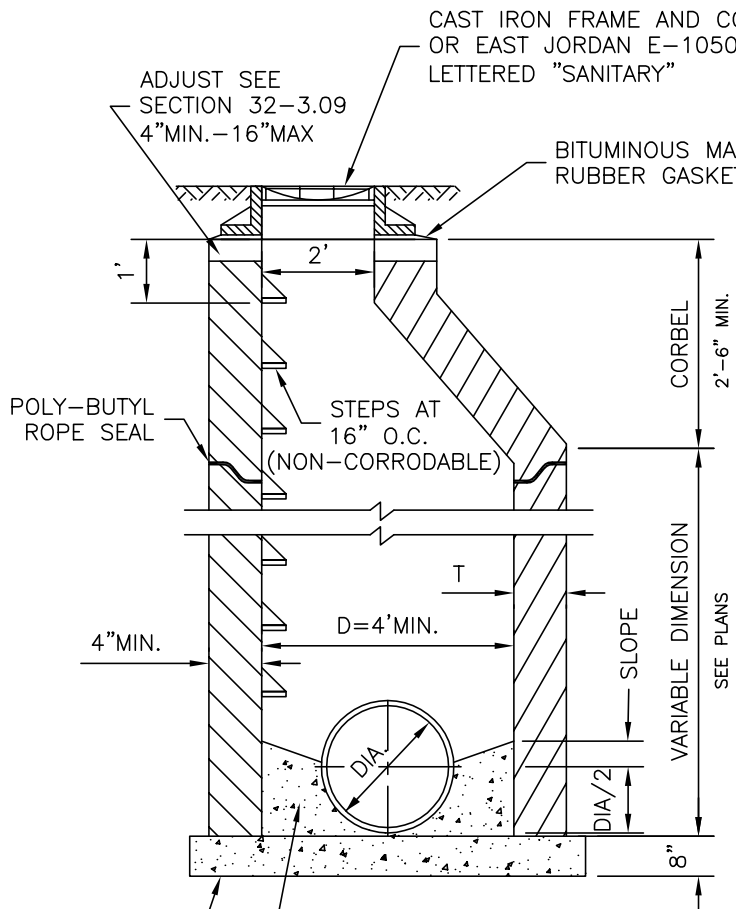

SECTION A - A

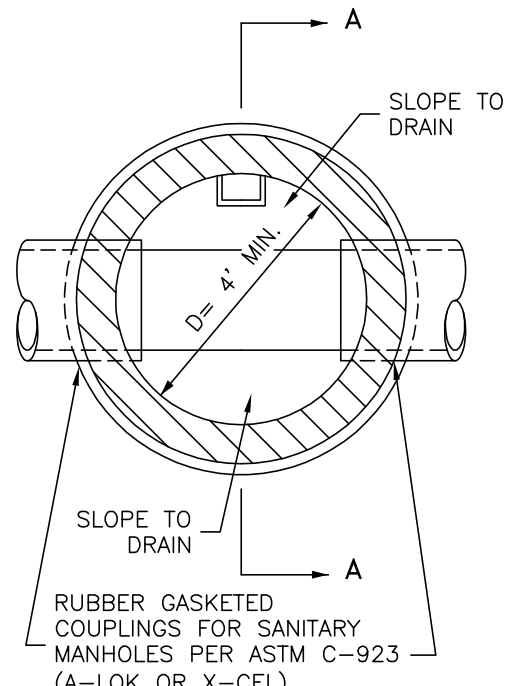

SECTIONAL PLAN

BOTTOM SLAB: PRECAST REINFORCED CONCRETE SLAB
 ON 6" SAND CUSHION BOTTOM SLAB SHALL
 BE PRECAST MONOLITHIC WITH MANHOLE
 WALL SECTION

NOTE: STEPS REQUIRED

NOTE: SANITARY SEWER MANHOLES SHALL
 BE EQUIPPED WITH EXTERNAL CHIMNEY SEALS
 (CRETEX, ADAPTOR INC. OR APPROVED EQUAL)
 WITH WATER TIGHT MANHOLE COVERS.

STANDARD SANITARY MANHOLE TYPE A	
CITY OF OTTAWA	DRG. 1
OCTOBER 6, 2008	